



NEW ZEALAND PONY CLUBS ASSOCIATION

PRIX CAPRILLI TEST Y — 2017

Regulation jumping helmets must be worn. Jumping whips are allowed, spurs optional. Breastplates, bandages or boots may be worn. Martingales may not be worn. Dressage whip may not be carried. Riders are expected to have shortened stirrup length

Bridle: ordinary snaffle
 Arena: 40 x 20 metres
 Time: 4 mins approx
 (Suggested Schedule Time 6 mins)

NOTE TO JUDGES:

This test is for riders and horses with some jumping experience. The rider must maintain a balanced position throughout. The horse/pony should be accepting the bit, maintaining an even rhythm and jumping calmly at the set pace. It is understood that in the working gaits, a jumping horse is not expected to be as round on the bit as a competing dressage horse. The horse must softly accept the bit and may show more "roundness" in the parts of the tests separate from the jumps. After jumping, horses may land in canter and make a balanced transition to working trot. Transitions into and out of the halt may be through the walk. Knockdowns will be penalized at the judge's discretion. In the case of a knocked down rail being in the way, the judge will ring the bell for the rider to stop without penalty. After the jump is replaced, the bell will be rung again telling the rider to continue from where he stopped.

1	A C	Enter at trot Track left	10
2	After A Opposite M	Turn down the ¾ line and over jump 1 Working trot	10
3	HXF F	Change the rein and over jump 2 Working trot	10
4	KXM C HEK K	Change the rein Medium walk Free walk on a long rein Medium walk	10
5	A FXH H	Working trot Change the rein and over jump 3 Working trot	10
6	Between H & C After C Opposite F	Working canter right Turn down ¾ line and over jump 4 Working trot	10
7	E HG GM	Walk Half circle right 10 metres Half circle left 10 metres	10
8	C H Between K & A After Opposite M	Halt approx 4 seconds. Proceed at walk Working trot Canter left Turn down the ¾ line and over jump 5 Working trot	10
9	HXF F	Change the rein over jump 6 Working trot	10
10	A G	Down centre line Halt, salute	10

Leave arena at a walk on a long rein at A

11		Impulsion and regularity of the paces	10
12		Suppleness, obedience, control and style	10
13		Position of the rider, correctness and effect of the aids	10

TOTAL 130



NEW ZEALAND PONY CLUBS ASSOCIATION

PRIX CAPRILLI TEST Y — 2017 Plan of Arena

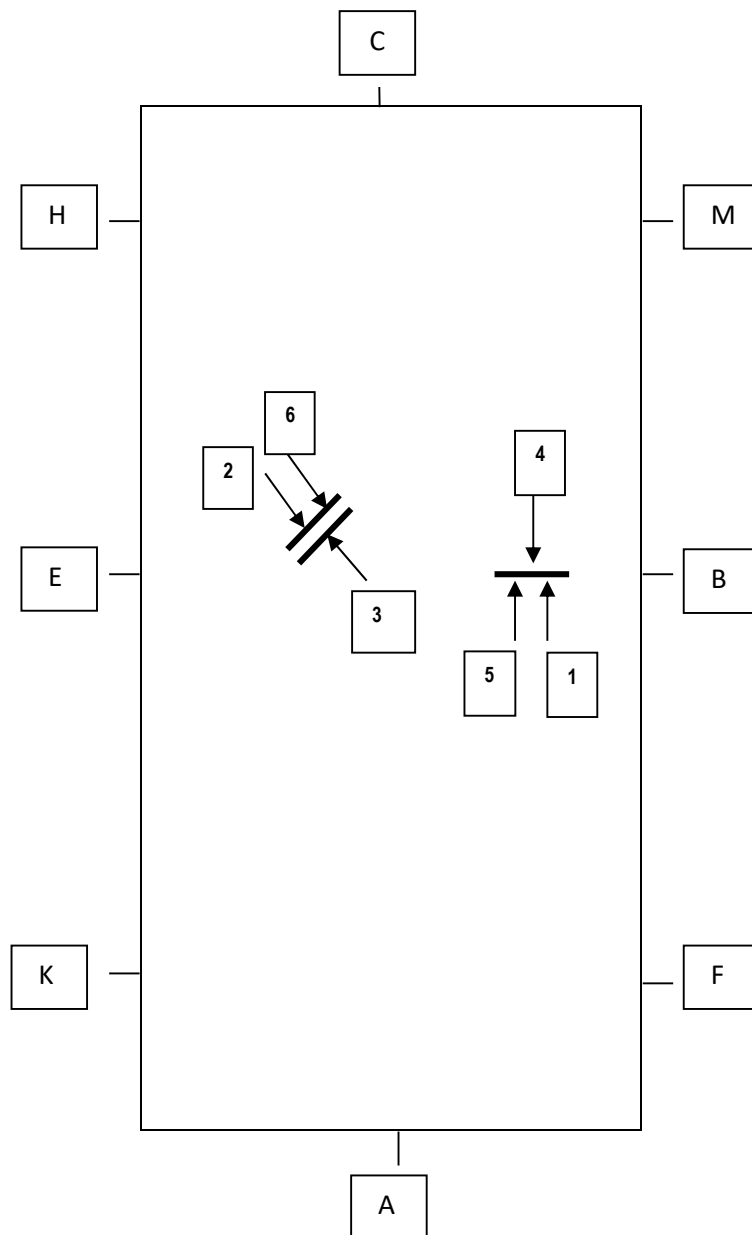

FENCES:

Maximum height 60cm

Fence 1, 5, 4 Vertical

Fence 2, 3, 6 Square Oxer

(Groundlines on both sides)

JUMPING PENALTIES:

Knockdown 4 faults

1st refusal 3 faults

2nd refusal 6 faults

3rd refusal Elimination

Fall of horse/rider Elimination

Regulation jumping helmets must be worn.

Jumping whips are allowed. Spurs optional.

Breastplates, bandages or boots may be worn.

Martingales may **NOT** be worn.

Dressage whips may not be carried.

Riders will be expected to shorten their stirrups

Centre of vertical approx 5m in from B

Place edge of vertical approx 2 - 3m in from B

Place square oxer on line between F and H, just past X